

# ARCHITECTURAL STANDARDS AND GUIDELINES

## TABLE OF CONTENTS

Includes changes approved.  
11-11-2022, 8-3-2023, 11-2-2023  
Effective January 5, 2024

- I. PURPOSE AND INTENT
- II. PHILOSOPHY
- III. BASIC PREMISES
- IV. DEFINITIONS
  - 4.01 ARCHITECTURAL REVIEW COMMITTEE
  - 4.02 BUILDER
  - 4.03 MASTER PROTECTIONS AND SINGLE FAMILY PROTECTIONS
  - 4.04 DECLARANT/DEVELOPER
  - 4.05 ASSOCIATION
  - 4.06 LOT
  - 4.07 BIRKDALE
  - 4.08 HOMEOWNER
  - 4.09 COVENANTS COMMITTEE
  - 4.10 ARC APPLICATION
  - 4.11 PLAN
  - 4.12 PROCEDURES
  - 4.13 AUTHORITY TO WAIVE REQUIREMENTS
  - 4.14 INTERPRETATIONS
- V SITE APPROVAL PROCEDURE
  - 5.01 SUBMIT SITE PLANS
  - 5.02 SETBACKS
  - 5.03 STAKING
  - 5.04 PLANS
  - 5.05 REVIEW PROCESS
- VI EXTERIOR STANDARDS
  - 6.01 ADDITIONS
    - 6.01.1 Application Requirements for Additions
  - 6.02 ANTENNAS

- 6.03 ATTIC VENTILATORS
  - 6.03.1 Application Requirements for the Attic Ventilators:
- 6.04 AWNINGS AND SUN TRELLISES
  - 6.04.1 Application Requirements for Awnings and Sun Trellises:
- 6.05 CHIMNEYS AND FLUES
  - 6.05.1 Application Requirements for Chimneys and Flues:
- 6.06 CLOTHESLINES
- 6.07 DECKS
  - 6.07.1 Application Requirements for Decks:
- 6.08 DECORATIVE OBJECTS (Exterior)
  - 6.08.1 Application Requirements for Decorative Objects:
- 6.09 DOG HOUSES AND DOG RUNS
  - 6.09.1 Application Requirements for Dog Houses and Dog Runs:
- 6.10 DRIVEWAYS
  - 6.10.1 Application Requirements for Driveways:
- 6.11 FENCES
  - 6.11.1 Permitted Fence Types
  - 6.11.2 Conditionally Permitted Fence Types
  - 6.11.3 Unacceptable Fence Types
  - 6.11.4 Application Requirements for Fences:
- 6.12 FLAGS AND FLAGPOLES
  - 6.12.1 Application Requirements for Flagpoles:
- 6.13 FOUNDATIONS
- 6.14 GARAGES
- 6.15 GARDENS, VEGETABLE
  - 6.15.1 Application Requirements for Gardens - Vegetable:
- 6.16 GREENHOUSES
- 6.17 GRILLS, BARBEQUES, and PITS (Permanent Structures)
  - 6.17.1 Application Requirements for Grills, Barbecues and Pits (Permanent Structures):
- 6.18 HEATING, AIR CONDITIONING UNITS, AND GENERATORS (Permanent)
  - 6.18.1 Application Requirements for Heating, Air Conditioning, and Generator Units:
- 6.19 HOT TUBS, WHIRLPOOLS AND SPAS
  - 6.19.1 Application Requirements for Hot Tubs, Whirlpools and Spas:
- 6.20 LANDSCAPING AND PLANTINGS
  - 6.20.1 Application Requirements for Landscaping and Planting:
- 6.21 LIGHTING (Exterior)
  - 6.21.1 Application Requirements for Lighting (Exterior):
- 6.22 MAILBOXES (Refer to Addendum 6.22.1 "Mailbox Diagram")
- 6.23 SIDING (Exterior)
- 6.24 PAINTING, STAINING, AND COLORS
  - 6.24.1 Application Requirements for Painting and Staining:
- 6.25 PATIOS AND WALKWAYS
  - 6.25.1 Application Requirements for Patios and Walkways:
- 6.26 PLAYHOUSES
  - 6.26.1 Application Requirements for Playhouses:

- 6.27 POOLS - (Private)
  - 6.27.1 Application Requirements for Pools - (Private)
- 6.28 RECREATIONAL/PLAY EQUIPMENT
  - 6.28.1 Application Requirements for Recreational/Play Equipment:
- 6.29 RESIDING AND RESTYLING
  - 6.29.1 Application Requirements for Residing and Restyling:
- 6.30 ROOFS
- 6.31 SERVICE YARDS
- 6.32 SIGNS
- 6.33 SOLAR COLLECTORS
  - 6.33.1 Application Requirements for Solar Collectors:
- 6.34 STEPS & PORCHES
  - 6.34.1 Application requirements for Steps and Porches:
- 6.35 STORAGE BUILDINGS
  - 6.35.1 Application Requirements for Storage Buildings:
- 6.36 STORM/SCREEN WINDOWS AND DOORS
  - 6.36.1 Application Requirements for Storm/Screen Windows and Doors:
- 6.37 SWIMMING POOLS - (Private)
- 6.38 TREE REMOVAL
- 6.39 WOODPILES

## VII OTHER STANDARDS

- 7.01 PROPERTY MAINTENANCE
- 7.02 TRASH (Refer to Section 6.31 Service Yards)
- 7.03 ANIMAL CONTROL
- 7.04 VEHICLES
- 7.05 PORTABLE TOILETS
- 7.06 PORTABLE STORAGE CONTAINERS

Exhibit 1: Birkdale Mailbox Diagram

Attachment 1: ARC Request Form



## I. PURPOSE AND INTENT

The Architectural Review Committee was established pursuant to the Master Protections, Article VI. It is empowered to establish and enforce standards and guidelines for new construction and modifications to existing construction. The Board of Directors, in the exercise of its power pursuant to Section 55-513(A) of the Code of Virginia and other sources, has also created a Covenants Committee to enforce compliance with Declarations, Articles of Incorporation, Bylaws and these guidelines.

These Architectural Standards and Guidelines are tools for homeowners and builders in the construction, addition, and alteration of single-family detached homes in Birkdale. They have been established for the preservation and enhancement of aesthetics and property values for the community.

These Standards are used by the Architectural Review Committee (ARC) as a basis for review of exterior building construction, additions or changes. The ARC is a volunteer workforce consisting of Birkdale homeowners. The Board of Directors has the authority to contract a professional review service for new construction when needed.

These criteria are in addition to the Master Protective Covenants and the Single Family Protective Covenants. They are intended to complement the Covenants. Should a conflict arise, the Covenants will prevail. These ARC Standards and Guidelines will follow to the greatest extent reasonable the standards established by Chesterfield County Board of Supervisors in the Zoning Ordinance, Code of Ordinances Section 19.2, or other ordinances. Other sections of the Code of Ordinances may also be used: e.g. swimming pools, vehicle parking, animal control, etc.

New Birkdale residents should read this booklet thoroughly before undertaking any type of exterior construction, change or addition. It contains information each builder and owner needs about the design review and approval process and procedures.

These standards and guidelines when implemented accordingly will be a primary factor to enhance value and promote common pride in the community.

## II. PHILOSOPHY

Birkdale is approximately a 500-acre planned community with 657 single-family lots. There are various architectural styles, lot sizes and configurations, as well as price ranges.

The common threads that provide continuity throughout Birkdale are quality and craftsmanship complimented by approximately 60 acres of common open areas. Mature white pines, hickory and oaks stand guard over most of the rolling countryside, while meadows provide open vistas in other areas. All these in conjunction with the green of the golf course, provide a rich natural environment, which reflects the image sought by Birkdale residents.

The British theme also reflects that traditional, graceful and elegant image. The name "Birkdale" was selected for the Royal Birkdale in England. Royal Birkdale is one of England's oldest golf clubs and was chosen for the site of the 1991, 1998 and 2008 British Open.

### III. BASIC PREMISES

The master plan for Birkdale was carefully planned to achieve the following objectives and features:

- 3.01. Maintain as much of the existing wooded and natural character of the land as possible.
- 3.02. Establish a tasteful private setting duplicating old world construction, tradition and simple elegance.
- 3.03. Design a unique residential and golf community of high quality.
- 3.04. Provide natural buffers to provide residents with privacy from other structures.
- 3.05. Provide for a plan of carefully placed lots to give owners full advantage of the area's natural beauty.
- 3.06. Appoint an Architectural Review Committee to strictly enforce the architectural and design elements of construction.

### IV. DEFINITIONS

#### 4.01 ARCHITECTURAL REVIEW COMMITTEE

The Architectural Review Committee (ARC) is established to protect the integrity of the community and is comprised of Birkdale Association homeowners. They do this by reviewing and approving or disapproving all plans for any type of exterior construction, alteration, erections, demolition, installation or enlargement of any building, fence, wall, accessory building, exterior lighting, sign, improvement or other structure. The ARC has the authority and responsibility to establish and maintain high quality design standards for structures and landscaping throughout Birkdale in conjunction with the Board of Directors.

While ARC approval must be obtained prior to construction, the Committee does not guarantee adequacy, technical sufficiency or safety or any proposed plan's compliance with applicable County Codes, Laws or Ordinances.

**ABSOLUTELY NO CONSTRUCTION OR MODIFICATION OF ANY TYPE CAN BEGIN UNTIL APPROVAL IS GIVEN BY THE ARCHITECTURAL REVIEW COMMITTEE.**

This Committee has the authority to administer procedures by which application submissions must be made in accordance with these directives. They also have the responsibility together with the Covenants Committee to enforce compliance with Standards and Guidelines and other provisions in the Master Protections on any new or revised project submitted to the ARC.

The ARC is appointed by the Board of Directors pursuant to the Master Protections and Covenants, Article VI, Section 6.1.

#### 4.02 BUILDER

An individual or corporation properly licensed by the Commonwealth of Virginia as a general contractor, constructing an individual house or houses at Birkdale. The ARC retains the right to accept or reject each Builder.

#### 4.03 MASTER PROTECTIONS AND SINGLE-FAMILY PROTECTIONS

The Declaration of Covenants, Easements and Restrictions recorded in the Clerk's Office of the Circuit Court of Chesterfield County, Virginia.

#### 4.04 DECLARANT/DEVELOPER

Crimson Birkdale, a Virginia general partnership, is the organization which originated the project. Crimson Birkdale and successive developers subdivided the land, built roads, utility lines and pedestrian paths. The Declarant/Developer term expired (effective November 2003, pursuant to the master covenants) and the Birkdale Community Association and the Birkdale Board of Directors are successor of interest and reserves the right to review, evaluate, and approve, disapprove, allow or not allow the use of all builder's and/or realtor's marketing, advertising, or construction programs related to the sale and/or construction or new homes to be built in Birkdale.

#### 4.05 ASSOCIATION

The Community Association is titled, "The Birkdale Community Association."

#### 4.06 LOT

Each of the 657 lots in Birkdale as shown on the subdivision plat upon which single-family residences may be or has been constructed.

#### 4.07 BIRKDALE

The land development in Chesterfield County, Virginia, known as Birkdale and shown on recorded plats.

#### 4.08 HOMEOWNER

The HOMEOWNER is defined as the owner of a building lot and any improvements thereon.

#### 4.09 COVENANTS COMMITTEE

The Covenants Committee is established by the Board of Directors to enforce community standards contained herein or in the Master Declarations or Single Family Protections. The Covenants Committee's responsibility includes areas not involving new construction, alterations, or other areas under the purview of ARC. The Covenants Committee may serve as an appeal point of ARC decisions. The Covenants Committee has primary responsibility to administer the Birkdale Community Association, Inc. Violations Complaint and Due Process Resolution current version as adopted by the Board of Directors.

#### 4.10 ARC APPLICATION

The process and form used to apply for plan approval so a homeowner may start construction, additions, or alterations to a lot. This procedure is defined in Section V. below.

#### 4.11 PLAN

The PLAN shall consist of a sketch, schematic, or formally prepared plans and specifications (A/E sealed) that show in sufficient detail the proposed construction, addition, or alteration to a lot.

#### 4.12 PROCEDURES

All construction on individual lots is to be reviewed by the ARC prior to beginning

\_. The ARC may meet formally or informally to discuss the submissions and their compliance with the Covenants and criteria contained here. The ARC has 60 days to review and notify the homeowner of the following decision:

- A. approve the plans in writing
- B. deny approval of the plans in writing, or
- C. approve the plans in writing subject to certain conditions or suggested changes.

The Declaration of Covenants in Section 6.3 states, "If the ARC does not approve or disapprove, or approve subject to conditions, any plans or proposed construction schedule within 60 days after it receives the same in compliance with section 6.2 of this Declaration, such plans (or construction schedule, as they may be) shall be deemed approved".

#### 4.13 AUTHORITY TO WAIVE REQUIREMENTS

The ARC has the authority to waive requirements in these Standards. They may do so only when the intent and quality required in design criteria are satisfied. Waiver of specific requirements must not be inconsistent with recorded Master Protections. Any such waiver must be in writing and must include a minimum of three (3) Board of Directors signatures. The waiver must be filed and maintained with the managing agent.

#### 4.14 INTERPRETATIONS

All interpretations of the contents of these Standards will be made by the ARC. In the event a homeowner does not agree with the ARC interpretations and a resolution cannot be reached, then the homeowner has the right to follow the Complaint Violation and Due Process procedure. The process has been implemented for a fair and impartial hearing to resolve such issues between the ARC and the homeowner.

### V SITE APPROVAL PROCEDURE

Prior to beginning new construction, one (1) site plan must be submitted and approved. \*NO LOTS WILL BE CLEARED UNTIL THE SITE PLAN HAS BEEN APPROVED.\*

#### 5.01 SUBMIT SITE PLANS

Draw parameters of the proposed structure on an enlargement of a lot drawing. Draw and label all corners of the house, garage, driveway, decks, porches, Florida rooms, etc.

#### 5.02 SETBACKS

All setbacks shall be governed by the Chesterfield County Zoning Code.

#### 5.03 STAKING

- A. Using a colored flagged stake, mark all corners of the building.
- B. Using a different colored flag, stake the outside limits of clearing for the driveway, beginning at the street right of way and ending with the outside limits of clearing for the house and yard.
- C. Using 2 different colored ribbons, mark trees to be saved within the overall clearing limits. Trees that have any flagging on them at all including the ones marking the clearing limit line will be considered as a tree to be saved.

## 5.04 PLANS

Plans must be professionally drawn by an architect or approved design service. No plans prepared by the owner (unless he is an architect) will be accepted for review by the ARC. The ARC reserves the right to request that all proposed changes to the plans be incorporated as part of the drawings if sketched changes are inadequate to convey the likely final appearance.

Even though a plan has been approved and built, it must be resubmitted and re-evaluated if being reproduced on another site or any exterior change has been made. Plans must be accompanied by a site plan drawn to scale showing the proposed location of the structure, setbacks, walks, and drives.

Reasonable efforts are to be made to ensure that no house may be repeated adjacent or directly across the street unless the exteriors are sufficiently different in design to provide an individual character to each house. This may be accomplished through the use of different door, window, and porch details, color or shutters, etc. The decision as to whether a design is "sufficiently different" will be at the discretion of the ARC.

## 5.05 REVIEW PROCESS

### A. NEW CONSTRUCTION

Complete architectural plans at  $\frac{1}{4}$  inch = 1 foot shall be submitted to the ARC along with the required site plan, and all exterior material and color selections. Plans will be approved only in conjunction with stake out review. Changes may be required by the ARC. For those lot buyers, a preliminary review is recommended prior to completing full working drawings.

A stake out of the house corners and flagging to indicate driveways and other clearing shall be reviewed and approved prior to any clearing.

The exterior of the house must be built in conformance with the plans submitted. Approved colors, proper treatment of driveways, provision of screening, and other requirements of these restrictions must also be complied with. A final letter of compliance for use in closing to assure compliance with the covenants shall be issued by the ARC only after a physical inspection has been made of the completed home with reasonable time of one week and notice being given by builder that the home is ready for inspection.

The ARC meets once a month or as needed and has 60 days to review and notify the homeowner of the ARC decision; see Section 4.09 Procedures.

The Board may contract a professional review service and the applicant will bear the cost for the review.

### B. MODIFICATIONS, ADDITIONS, AND CHANGES

Modifications, additions and changes shall be submitted to the ARC using the ARC Request Form, Attachment 1, included in this procedure. Specific requirements in the Form must be followed including detailed description of the proposal, acknowledgement signatures of adjacent owners, and the Owner's Understanding and Agreement. The application may be submitted in writing or electronically as indicated on the form. Reply of the committee will be in writing and will become a part of the homeowner's permanent file with the association through the managing agent.

Proposals which affect the exterior of a structure including decks, fences, driveways, storage buildings or other elements may require submittal of a survey, plot plan, or similar document sufficient to assure to the ARC Committee that no property encroachment or property line violation will occur by approval of the project. Approval of a project by the ARC Committee does not constitute approval of a property line encroachment nor compliance with applicable building codes.

Certain items which do not require approval may be submitted for record keeping purposes to document when the changes were done. Examples are roof replacement, storm doors, windows, and painting.

## VI EXTERIOR STANDARDS

### 6.01 ADDITIONS

Any extension or attachment of the residence is considered an addition. Building additions include but are not limited to garages, greenhouses, porches, and rooms (three-season or four-season). Three-season rooms are those that are enclosed but are not heated. Access to a three-season room is usually entered by a doorway from the main part of the house; hence they are not "open" to the main part of the house as are four-season rooms (an enclosed room/area which is heated). Any new construction/addition (not a conversion of an existing screened porch) shall have a foundation consistent with the attached house, i.e., a full foundation or engineered brick piers. Chesterfield County has no specific foundation requirements with respect to converting an existing screened porch into a three-season or four-season room. Screening beneath all porches shall consist of lattice as approved by the ARC. The design of additions must be consistent with the existing shape, style and proportion of the existing residence. Carports are not permitted in Birkdale. A deck is not an addition; see article 6, Section 7 for deck installation and modifications. For foundation requirements on new construction see 6.13.

- A. The finish and color of siding, roofing, trim materials, etc. must match those on the existing house. Regardless of materials used, colors shall match; obvious color differences are not acceptable and shall be changed to match.
- B. The style and color of new windows and doors must match those on the existing residence. They must also be located on walls at the same approximate height and vertical plane as the originals.
- C. Roof eaves and fascias must be the same depth, style and approximate height and all roof slopes proportionate to the original.

- D. Additions must be located to not impair the view, amount of sunlight, or ventilation of adjacent residences or the public's use or enjoyment of open space. New windows, doors, or viewing areas from the addition must not infringe upon existing internal or external private areas of adjacent properties.
- E. Additions must be located to not adversely affect drainage conditions on adjacent properties through changes in topography.
- F. Additions must show details of the lighting scheme and proposed fixtures (See Section 6.21 Lighting).
- G. Garages converted to living space must match the existing house (windows and foundation). If the garage is converted, then a pedestrian door shall not be allowed to be placed where the garage door was previously.

#### 6.01.1 Application Requirements for Additions:

- A. The following must be submitted with the completed application.
- B. Two site plans and complete set of architectural drawings paralleling those required for Chesterfield County building permits.
- C. The site plans must show relationship of proposed and existing construction to property lines and adjacent residences and include size and location of trees in affected areas.
- D. Drawings to scale of proposed construction must include elevation views of each proposed exterior wall including dimensions and locations of doors, windows, rooflines, trim and proposed exterior lighting including fixture type.
- E. A complete description of materials including manufacturer and type of siding, roof, trim, colors, etc.

NOTES: (1) Commonwealth law requires locating existing underground utilities prior to digging for installation of underground wiring or to install light fixtures. Call Miss UTILITY of VA at 1(800) 552-7001.  
(2) For building permit information contact Chesterfield County.

#### 6.02 ANTENNAS

Satellite dishes exceeding 1 meter in diameter are prohibited. A single and smaller satellite dish is permitted in the rear yard or on the rear roof/line preferably not visible from the street. Satellite dishes are prohibited in the front and side yards or on the front roof/line unless an adequate signal cannot be obtained elsewhere on the property. Planting of screening shrubs may be requested by the ARC for satellite dishes/antennas placed in yards. With respect to erection of antenna types other than satellite

dishes, an application to the ARC is required, and the applicable Virginia code will apply. See Section 3.10 of Single Family Protections.

### 6.03 ATTIC VENTILATORS

An application is not required for attic ventilators on the exterior of a residence provided the following criteria are met:

- A. The ventilator is roof mounted and is located on the least visible side of the roof (from the public street view) and does not extend above the ridgeline.
- B. No part of the ventilator protrudes more than 12 inches above the roof surface.
- C. Should it become necessary to block the airflow, it must be blocked from the inside of the structure.

#### 6.03.1 Application Requirements for the Attic Ventilators:

The following must be submitted with the completed application.

All installations which do not meet the above provisions require an application describing the ventilator in detail and showing its location and elevation above the roof plane.

### 6.04 AWNINGS AND SUN TRELLISES

- A. Sun control devices must be compatible with the architectural character of the residence.
- B. Awnings must compliment the color and design of the house.
- C. Awnings and sun trellises must be consistent with the visual scale of the residences to which they are attached.
- D. The location of any awning or trellis must not adversely affect views, sunlight or natural ventilation of adjacent properties. Awnings are not permitted on the front or side of the residence. Pipe frames for canvas awnings must be painted to match the trim or dominant color of the house. Awnings must be a permanent year-round fixture.

#### 6.04.1 Application Requirements for Awnings and Sun Trellises:

The following must be submitted with the completed application:

- A. A detailed drawing of the trellis or awning showing dimensions and a description of the method of support and attachment to the structure.

- B. A description of the color and style of the sun control device and of the residence to which it is to be attached, including a description of the materials to be used.
- C. An explanation of the impact, if any, the sun control device will have on adjacent residences.

## 6.05 CHIMNEYS AND FLUES

The purpose of this section is to ensure that exterior chimney installations will be in harmony with the applicant's house and surrounding properties.

These guidelines encourage the use of masonry (brick or stone) or siding enclosed construction.

- A. Brick chimneys are mandatory on traditional homes (i.e., Colonial, Victorian, Tudor, French provincial, Spanish, etc.) that have fireplaces. Direct vent gas fireplaces are allowed.
- B. Traditional homes with brick chimneys shall also have two separate sets of washes in the chimney with the second set at the cornice line. The chimney base shall be a minimum of 10 bricks in width, narrowing at the first wash set to a minimum of 8 bricks, narrowing at the second wash set with a minimum of 6 bricks. In Sections 1, 2, and 3 and sections developed thereafter, traditional homes shall have one set of washes in the chimney.
- C. Brick chimneys shall be at the discretion of the ARC on contemporary homes. If a prefabricated chimney is used; it must have no cantilever, and a foundation must be provided. Chimney caps must be approved by the ARC in Sections 1, 2, and 3 and sections developed thereafter, however they must be black and not more than 11 inches tall. Metal caps on top of the chimneys are discouraged. In Sections 1, 2, and 3, and sections developed thereafter, the metal cap on top of the chimney shall not be installed.
- D. The chimney must be boxed-in if it is to be located on the front slope of the roof or the roof ridge, or any other location where it will be highly visible from the fronting street. Locations on the front slope of the roof should be avoided
- E. In all cases the boxed-in chimney must be constructed to a required height of 4' above the roofline of the main portion of the house.
- F. In Sections 1, 2, and 3 and sections developed thereafter, chimneys shall have a 2' clearance when attached to the main body of the house.
- G. The following guidelines apply in addition to those above when there is no existing chimney on the house other than a builder-provided through-the-roof installation for the central heating system. Special care is needed to arrive at an architecturally suitable design when a second chimney is to be added. Each case will be considered separately, with the following criteria considered:

- a. Dissimilar chimneys must not be used unless it is impossible to see both at the same time.
  - b. When a second chimney is to be added on the same side of a house as an existing boxed-in chimney, every effort must be made to see that both flues run through the same enclosure.
  - c. When a second chimney is to be run along a different wall than the first, it must be of the same design as the first.
- H. All chimneys and direct vent fireplaces constructed of brick are required to have a foundation.

#### 6.05.1 Application Requirements for Chimneys and Flues:

The following must be submitted with the completed application:

- A. A description of the applicant's house, including style, siding, shutters type, decorative embellishments, etc., and a photograph of the front of the house and the proposed location of the chimney.
- B. A site plan showing the location of the proposed chimney and its relationship to the house, property lines and adjacent residences.
- C. A detailed drawing showing exterior elevations and dimensions of the proposed chimney.
- D. A complete description of the proposed chimney and exterior construction materials, including type and color of masonry or siding material to be used. The relationship of these materials and colors on the house must be included.
- E. Where there is an existing chimney (other than a builder-provided through-the-roof installation), provide details as in "A" through "D" above for the existing chimney.

#### 6.06 CLOTHESLINES

- A. No clotheslines or other clothes drying apparatus will be permitted.

#### 6.07 DECKS

NOTE: Chesterfield County requires a building permit for installation of a deck. Additionally, approval is required by the ARC for the building of all decks. The following criteria will apply to the construction of decks.

- A. Decks must be constructed of durable materials such as brick, stone or pressure-treated wood, synthetic, composite, or recycled materials if the materials provide comparable strength and appearance of wood. Lattice, post and rails must be constructed of similar durable decking materials or vinyl. Vinyl must conform to the American Society for Testing and Materials (ASTM) standard ASTM F964. Stair stringer material must be of metal or wood construction.
- B. The color of each deck must match the primary color of the residence exterior, its trim or be a natural wood color. If the color of the deck does not match either the primary exterior color or the trim color of the house, a color sample for the proposed deck, the house and the trim must be submitted with the application.
- C. In addition to the above, decks will be considered on their individual merit, which includes, but is not limited to location, size, conformity with design of the house, relationship to neighboring residences and proposed usage.
- D. All decks must have adequate screening to conceal the underside of the deck. Screening is to be by lattice work or wood of the same color and texture of the deck, or by plantings to provide cover and to enhance the overall view of the property. Any exceptions must be approved by the ARC.
- E. No supports for decks to be less than 6" x 6" pressure treated posts.
- F. Privacy screens may be constructed on decks at the sole discretion of the ARC. Such screens may not exceed seven feet in height measured from the deck floor.
- G. All steps facing the golf course or visible from a street shall have closed and painted or stained risers.

#### 6.07.1 Application Requirements for Decks:

The following must be submitted with the completed application.

- A. A site plan with dimensions showing the relationship of the deck to the house, property lines and adjacent residences.
- B. Any changes in window or door locations must also be shown; including the conversion of a window opening to a door opening or vice versa.
- C. A descriptive drawing including dimensions height above grade and details of posts, railings and stairs.
- D. A description of materials and color of the proposed deck and those of the house.
- E. A description and proposed relocation site of any plantings, equipment such as meters, air conditioners, heat pumps, etc. to be moved for the construction of the deck.

- F. A description of proposed changes in exterior lighting.

## 6.08 DECORATIVE OBJECTS (Exterior)

- A. Applications and approval will be required for all permanent exterior decorative objects, natural or manmade, that are visible from the street.
- B. Objects will not be evaluated solely on aesthetics but also on-site location, proportion, color, and appropriateness to surrounding residences, properties and environment.
- C. Holiday and festival decorations do not require approval; however, the placement of conspicuous decorative objectives must coincide with the holiday. Holiday decorations shall be removed no later than 14 days after the observed holiday.

### 6.08.1 Application Requirements for Decorative Objects:

- A. A site plan must be submitted with the completed application showing the proposed location of the object, its size, color and detailed drawing or picture of the object.

## 6.09 DOG HOUSES AND DOG RUNS

Written approval from the ARC is required for construction of all doghouses and/or dog runs. The following criteria apply. NOTE: Chesterfield County has ordinances regarding treatment of animals, leash laws and noisy pets.

- A. Doghouses must be of the same siding and roofing materials and color as the residence.
- B. Dog runs must be as close to the residence as possible and in the rear of the lot. Dog runs and dog houses must NOT be located on or near property lines or on a public road right of way. Visual screening from adjacent properties is required by means of plantings, approved fencing, etc. For fences see 6.11 FENCES.

### 6.09.1 Application Requirements for Dog Houses and Dog Runs:

The following must be submitted with the completed application.

- A. A site plan showing relationships of dog runs and/or houses to the applicant's residence, adjacent properties and residences and other identifiable landmarks, including roadways.

- B. Detailed drawings of the house or run to indicate dimension; a list of materials to be used for construction; and pictures of the proposed area for the dog run in relationship to the residence and adjacent properties to be submitted with the application.

## 6.10 DRIVEWAYS

- A. An application is required for any driveway construction or expansion.
- B. Driveways where space permits must curve into a site in order to provide the maximum natural tree cover or landscaping between the house and the street. Circular drives may be permitted with prior approval.
- C. Driveways are to be constructed of exposed aggregate concrete, plain or colored concrete or asphalt. Loose gravel/stone driveways, or expansion thereof are expressly prohibited.
- D. Application is NOT required for the replacement of an existing driveway when there is no change in location, materials, size, shape or grade.

### 6.10.1 Application Requirements for Driveways:

The following must be submitted with the completed application.

- A. A site plan with dimensions showing the relationship to the applicant's residence, trees, property lines, adjacent properties or residences.
- B. A description of materials to be used, including color and texture.
- C. A drawing showing the thickness and subsurface preparation.
- D. A description of proposed changes in grade and drainage.

## 6.11 FENCES

Specific limits are placed on the types of fences and the extent of fencing approved in Birkdale in order to protect the open character of the landscape. The purpose of these standards is to provide each residential lot with the atmosphere of a larger open area.

### 6.11.1 Permitted Fence Types

- A. Permitted fences on all lots includes unpainted split rail, unpainted board rail, unpainted picket, factory colored vinyl picket, and black metal picket.

- B. All permitted fences shall be constructed of unfinished pressure treated wood, or factory colored vinyl or factory painted metal. . A homeowner may submit samples and manufacturing specifications of a synthetic material to the ARC for consideration and approval; the material must be of comparable strength, appearance and life as that of wood or, vinyl or metal.
  
- C. All permitted fences in this section are limited to a minimum of 3' 6" to 4'-0" in height from the ground to the top of the top rail or top of pickets. Fences may be taller if designed as a swimming pool barrier fence system. Rail fences shall have a minimum of three rails unless otherwise approved by the ARC. Picket fences shall be open spacing style with a minimum of one inch between pickets. Black metal fences shall comply with design specifications stated below. Placement of fences in proximity to the side and rear lot lines shall be governed by state and local ordinances and restrictions. Fences constructed on or through easements are done so at the sole risk of the owner.
  
- D. The ARC permits only one fence along the common lot line (back, side, etc.). If a homeowner requests installing a second fence along the common lot line where a fence already exists, the ARC shall require no less than a two-foot (2') separation between the fences to provide for ample space for grounds and fence maintenance.
  
- E. Posts and framing shall be set to the inside of the fenced area with rails or pickets facing out.
- F. Fences may not be installed further forward on the lot than the back plane of the home.
  
- G. A 2" x 4" mesh welded wire fabric may be used to line the inside of rail or board fences.
  
- H. Discontinuous or short sections of fence used solely as an element of landscaping design may be permitted in front yards at the discretion of the ARC. Application for these fences must include landscape designs.
  
- I. If common areas of the Association become inaccessible due to the construction of fences by lot owners, then it shall be the responsibility of the lot owners to maintain that common area.
  
- J. Gates are required for fences which border the golf course to enable players access to golf balls.

K. Vinyl fencing and material must be factory colored white or a factory-colored natural wood color and must conform to the American Society for Testing and Materials (ASTM) standard ASTM F964: Standard Specification for Rigid Poly Vinyl Chloride (PVC) Exterior Profiles Used for Fencing (or equal performance standard).

L. Black metal fences may be constructed on aluminum or steel. Fences shall be no taller than four feet at the posts. Fence top design may be concave, convex, or straight and may include two rails in the upper portion. Vertical pickets shall be evenly spaced 3-4 inches apart. Security screening may be installed on the inside of the fence.

### 6.11.2 Conditionally Permitted Fence Types

- A. If a homeowner's property line is adjacent to a property line that is outside of the Birkdale community, the homeowner has the right to request a special exception for a fence type to block the exterior view. This must be done in writing to the ARC in the form of an application. No application will be approved without a meeting of the ARC with the homeowner to discuss the area to be fenced.
- B. The views that may be blocked are any non-Birkdale community land, such as utility easements, or land that is not part of the Birkdale Association. Other exterior views may be blocked but it will be at the discretion of the ARC based on the application submitted by the homeowner in determining approval.
- C. The fence used in this area may be a maximum of 6 feet in height when measured from the ground to the top of the fence. It may be a full privacy fence with no spacing in-between the pickets, but only when used along the property line that is adjacent to the non-Birkdale community view. Other approved fencing material will be considered if it conforms with Section 6.11.1 Permitted Fence Types. A homeowner cannot block any view of the golf course with a fence of this type (i.e. privacy fence).
- D. Any posts and framing for these fences must be on the inside of the area fenced and only viewable from the homeowner's property.
- E. Additionally, the homeowner is permitted to screen portions of the fence with landscaping, using evergreens to create a natural view. The proposed plantings must be included in the application for approval by the ARC.

### 6.11.3 Unacceptable Fence Types

The four (4) style fences below will NOT be permitted in Birkdale:

- A. Chain link fence
- B. Barbed wire fence
- C. Metal or wood post and wire fence
- D. Stockade fence (pre-assembled untreated wood fence made with rounded pickets with pointed tops)

#### 6.11.4 Application Requirements for Fences:

A site plan must be submitted with the completed application showing the relationship of the proposed fence and gates to adjacent properties and residences, type of fence to be installed, design or plans of fence, materials to be used and recognition of property lines.

### 6.12 FLAGS AND FLAGPOLES

Written approval is required for any free-standing flagpole detached from the house.

#### 6.12.1 Application Requirements for Flagpoles:

The following must be submitted with the completed application.

- A. Written approval is not required for a single decorative flag to be flown from flag standards of 6' or less in length mounted on the front and back of the house. A single flag can be displayed under the mailbox and in front of the mailbox post.
- B. Free standing flagpoles detached from the house are not permitted in the front of the house.
- C. A single flagpole not exceeding 15' in height, may be permitted in rear yards directly behind the house, but no closer than 15' to any property line.
- D. Approval of flagpoles on all corner lots will be considered on an individual basis.

### 6.13 FOUNDATIONS

- A. Houses must be designed and located to minimize exposed foundations. Some grading of the site and siding to grade are acceptable means of disguising visually awkward foundations.

- B. Exposed foundations must be brick on all residences and shall have dark sand in the mortar. Stucco or other approved materials may be used on contemporary residences but must be applied with a 3-coat process and should be used only when consistent with the overall design intent of the house. Parged, painted or exposed concrete block are not acceptable and will not be approved.
- C. Wooden foundation vents shall be utilized on all homes on Royal Birkdale Drive. Homes constructed on corner lots shall be considered on an individual basis as to whether wood vents will be used on both "street sides" of the home. For example, heavily treed lots may or may not require wooden vents on two sides.
- D. On all additions the brick, mortar, and vents shall match that of the existing foundation. See 6.01 ADDITIONS.

#### 6.14 GARAGES

- A. Construction of garages falls under the guidelines of additions. SEE 6.01 ADDITIONS. Carports are not permitted in Birkdale.
- B. Garage Entrances - Front garages with side entrances are encouraged since shorter drives, less disturbance of vegetation, less disruption to neighbors and clear views of the golf course are achieved.
  - a. Front entry garages may be permitted when the driveway and landscaping are designed to minimize the dominance of the garage doors. Front entry garages are not permitted on lots facing Royal Birkdale Drive developed prior to Section 9.
  - b. Side entry garages will require a minimum of 5' of natural or landscape buffer to be incorporated between the back out space and the lot line.
  - c. Rear entrance garages on golf course and lake front lots will require a minimum of 5' of natural or landscape buffer to be incorporated around back lot space.
  - d. No garage on a corner lot may face Royal Birkdale Drive for lots developed prior to Section 9.
- C. Garages for new construction are required to be attached to houses. Any exceptions must be approved by the ARC.
- D. Garages converted to living space must match the existing house (windows and foundation). If the garage is converted, the garage door and opening must remain.

- E. Garage doors shall generally retain the original color and style. However, painting may be permitted subject to review by ARC. Colors shall either be wood tones or a compatible primary color of siding, trim, or shutters in accordance with section 6.24.E.a.

## 6.15 GARDENS, VEGETABLE

- A. Only a single garden/vegetable plot per residential lot is permitted. The plot must be located behind the rear sight line of the house: the exception to this is that houses set on corner lots or on lots at angles must be placed in the most inconspicuous area of the lot.
- B. No approval is required for a garden plot less than 150 square feet.
- C. Temporary screening or fencing may be used to keep out small animals; total height, including supports, not to exceed 18 inches. Temporary fencing may be installed at planting and must be removed at the end of the growing season.
- D. At the end of the growing season, all dead plants must be removed, and the ground put back to the original grade. It is suggested that bare earth be covered with straw mulch or similar cover to prevent soil erosion.
- E. All garden materials must be stored behind the service yard area, or in a shed or garage. Refuse must be placed in proper containers for disposal and not placed on rights of way or open spaces.
- F. If based on valid complaints received from adjacent homeowners or from observations via the ARC project inspection, the homeowner fails to correct the violation (to comply with this section), and then the ARC has the authority to require removal of the garden.

### 6.15.1 Application Requirements for Gardens - Vegetable:

The following must be submitted with the completed application for a garden larger than 150 square feet.

- A. A site plan with exact location of the garden in relationship to the residence and property lines; dimensions of the garden are to be included.
- B. Renewal applications are not required on an annual basis for a plot of less than 150 square feet. However, any change in size or location of a previously approved garden plot requires reapplication.

## 6.16 GREENHOUSES

- A. A detached greenhouse is considered a structure and requires approval prior to construction. See 6.01 ADDITIONS.

## 6.17 GRILLS, BARBEQUES, and PITS (Permanent Structures)

NOTE: Residents are advised to ensure that the location of any of these structures does not violate the Chesterfield County Fire Code.

- A. ARC approval is required for all grills, barbeques and pits which are incorporated into or are considered a permanent structure.
- B. Grills must be located behind the rear sight line of the house and at least 10' from any property line.

### 6.17.1 Application Requirements for Grills, Barbecues and Pits (Permanent Structures):

The following must be submitted with the completed application.

- A. A site plan showing the relationship of the proposed location to the applicant's residence, adjacent properties and residences.
- B. A detailed drawing showing design, dimensions and list of materials to be used in construction must be submitted with the application.

## 6.18 HEATING, AIR CONDITIONING UNITS, AND GENERATORS (Permanent)

- A. All outdoor heat-exchange, air conditioning, or generator units must be located at the rear or side yard of the residence and must be adequately screened from adjacent properties.
- B. Wall and window air conditioners shall not be visible from the street.

### 6.18.1 Application Requirements for Heating, Air Conditioning, and Generator Units:

The following must be submitted with the completed application.

- A. A site plan showing the proposed location of the unit in relationship to the residence.
- B. A description and drawing or picture of the unit, including dimensions.
- C. A proposed screening and landscape plan.

## 6.19 HOT TUBS, WHIRLPOOLS AND SPAS

Hot tubs, whirlpools, and spas must comply with the Chesterfield County code for swimming pools if they fall under the definition. See section 6.27.

- A. An application is required for any exterior hot tubs, whirlpool or spa. The location must be behind the rear sight line of the house. All such facilities must be adequately screened from adjacent properties.
- B. The hot tub, whirlpool or spa must be of materials that will blend with the surrounding residences. A childproof lid is encouraged.

### 6.19.1 Application Requirements for Hot Tubs, Whirlpools and Spas:

The following must be submitted with the completed application.

- A. A site plan showing the location of the hot tub, whirlpool or spa and its relationship to existing residences and property lines.
- B. The dimensions, type and color of proposed materials.
- C. Proposed screen and landscaping plan.
- D. If necessary, Chesterfield County authorization should be included.

## 6.20 LANDSCAPING AND PLANTINGS

Preservation of natural features and the feeling of openness contribute greatly to Birkdale Community's difference from typical developments. Topographic and vegetation characteristics of lots must not be altered by removal, reduction, cutting, excavation, or any other means without the prior written approval of the ARC.

- A. Initial Landscaping Budget:
  - a. At the initial installation, all houses must incorporate a minimum landscape budget of \$1,000.00 for plants which include a minimum of 20 plants; however, this budget does not include labor, mulch, irrigation, topsoil, or site grading. The initial landscape plan must be submitted to the ARC for approval.
  - b. All front and side yards are required to have sod and irrigation installed to the rear house line and side property lines exclusive of approved landscape planting beds, sidewalks, and driveways. The builder shall maintain the sod in accordance with industry practices until closing.

- c. All rear yards not containing sod in accordance with item (b) above and not landscaped in accordance with an approved landscape plan shall be seeded with a turf grass seed compatible with the sod grass installed.

B. General Requirements:

- a. It is recommended that plantings be arranged in clusters or groups rather than in straight lines in order to present a natural effect. Care must be taken not to over plant one's lot with random plants and trees. Unnatural materials such as plastic fencing, artificial flowers and painted rock are not allowed.
- b. When having mulch or other bulk materials delivered, the homeowner is required to have items placed on your own property, not on streets, sidewalks, open space, rights of ways, etc.

C. Post-Closing Lawn/Landscaping- The following major landscaping projects of the homeowner do not require ARC approval:

- a. Adding shrubs, planting grass and/or ground cover and pruning of existing plant material.
- b. Planting trees and shrubs, which at maturity, the drip line does not encroach on the adjacent property line.
- c. Discontinuance or short sections of fences (split rail or picket fences) can be no higher than three feet and no longer than six feet and must be solely used in a landscaping setting in the back yard,
- d. Adding mulch, bark or river rock as landscaping features or plant enhancement.

D. Approval is required for but not limited to, the following:

NOTE: All trees, regardless of size, located in the common areas can only be maintained or removed at the direction or approval of the Board of Directors.

- a. Removal of any live tree whose trunk is over 10" in diameter when measured 2' above the ground. No prior approval is required for removal of dead or diseased trees. Storm damaged trees may be removed or trimmed without prior approval.
- b. Hedges are discouraged but will be considered on an individual basis. Maximum hedge height must not exceed 4 feet.

- c. Any earthwork creating changes in topography, site drainage or creation of ponds, pools or other water features.
- d. Screening plants must be fast growing in order to provide effective screening.
- e. Retaining walls or similar structures.
- f. Discontinuance or short sections of fences (split rail or picket fences) that do not meet the requirements in section 6.20, C.3 Post Closing Lawn/Landscaping.

### 6.20.1 Application Requirements for Landscaping and Planting:

The following must be submitted with the completed application:

- A. A description of the type and size of plantings to be planted complete with plan showing the relationship of plantings to the residence, properties and adjacent residences.
- B. A brief description of any tree to be removed and the reason for the removal.
- C. A description of any retaining wall or similar structure, complete with materials and construction method with a rationale for the construction, location on the property and location to adjacent properties.

### 6.21 LIGHTING (Exterior)

NOTE: Commonwealth law requires locating existing utilities prior to digging for installation of underground wiring or to install light fixtures. Call MISS UTILITY of VA at 1 (800) 552-7001. See Section 6.01 ADDITIONS.

- A. General — Exterior lighting fixtures shall be limited to lights at home entrances; garage doors, low intensity/LED landscape or driveway lights, side, or rear only eave-mounted floodlights and shall be compatible with the style of the house or existing lighting.
- B. Applications for exterior additions, such as garages, must include details of lighting fixtures proposed. Fluorescent tube lighting installed out-of-doors will not be approved. Compact fluorescent lighting (CFL) is acceptable. LED lighting may be allowed depending on the brightness.
- C. Proposed permanent exterior lighting and wiring requires written approval. All exterior lighting must be installed in such a manner that it will not shine on adjacent property, open space or public rights-of-way, and must be aesthetically planned for each location. Approval for floodlights and various types of high output lights must be contingent upon impact on neighboring properties and roadways. Light fixtures of this type must be carefully positioned so that they illuminate only a specific area. High output light fixtures may have to be shielded in a manner similar to street light installations to prevent unwanted or excessive intrusion of light from one property to another.

- D. Temporary lighting - Holiday and festival lighting do not require approval; however, the operation of festival and holiday lighting must coincide with the holiday and be removed no later than 14 days after the observed Holiday.
- E. All pole lamps (front yards) must be approved by the ARC. The ARC will approve these based on lamp style compatibility with the house and the general lamp use in the area or section.

#### 6.21.1 Application Requirements for Lighting (Exterior):

The following must be submitted with the completed application.

- A. A detailed drawing of exterior light placement on a site plan.
- B. A drawing or picture of fixture to be installed and its location.
- C. A description of the impact of proposed lighting on properties.

#### 6.22 MAILBOXES (Refer to Addendum 6.22.1 "Mailbox Diagram")

All mailboxes must be of the design and type approved by the ARC.

Mailboxes and all posts must be maintained in good condition in accordance with Exhibit 1. for design and specifications and the below standards. Materials for mailbox posts and supports shall generally be pressure treated wood; however, PVC may be used in trim areas and media boxes. The only approved color combinations for mailboxes and posts are the following:

- A. For all wood sections, including but not limited to the post and media box section:
  - a. Quart Size, Base color N103-1B comprised of pigment mixtures YW Ox 1.7500, OY Ox 1.7500, and GY Ox 2.2500; or
  - b. Gallon Size, Base color N103-1B comprised of pigment mixtures YW Ox 7.000, OY Ox 7.000, and GY Ox 9.000.
- B. For the mailbox only:
  - a. Quart Size, Base Color 110-4B comprised of pigment mixtures RX Ox 22.0000, BK Ox 9.5000, and MA lx 6.000; or
  - b. Gallon Size, Base Color 110-4B comprised of pigment mixtures RX 2x 24.0000, BK lx 6.0000, and MA 4x 24.000.

These are Birkdale official pigment statements for the approved colors. They are Benjamin Moore colors which can be purchased from Spectrum Paint Company with the named colors of Vanilla Cookie for the wood sections, and Cottage Red for the Mailbox. Other suppliers colors may not be acceptable.

- C. The only approved Birkdale Logos and street numbers are available from Post Net or The MailBox Guy. These logos and numbers are placed flush against the wooden section of the newspaper section as shown in Exhibit 1. Raised numbers are not allowed. Contact information:
  - a. Post Net, 13926 Hull Street Road, Midlothian, VA 23112  
Phone 804-739-8828, email [va125@postnet.com](mailto:va125@postnet.com)
  - b. The MailBoxGuy, Rich McGuiness, 9231 Mission Hills Lane, Chesterfield, VA 23832  
Phone: 919-621-9983, email: [TheMailboxGuy@yahoo.com](mailto:TheMailboxGuy@yahoo.com)
- D. No other decorations, coverings, or alterations to mailboxes are allowed on or to the mailbox and post, except as holiday decorations or seasonal planting.
- E. Mailbox sizes must comply with US Post Office Standards. Two sizes of traditional mailboxes are acceptable: (a) 18.5 " x5 " x 6". Or (b) 19"x 6" x 76".

## 6.23 SIDING (Exterior)

Vinyl siding may be permitted in all sections at the discretion of the ARC. The following criteria shall be used by the ARC in judging the acceptability of any vinyl products submitted:

- A. Requests for approval of vinyl siding must be accompanied by manufacturer's product specification sheet, physical samples of product, style, color desired, and details and samples of proposed trim pieces and their locations.
- B. The submitted product must be the manufacturer's Premium Grade Vinyl product not to be less than .044 inches in thickness as evidenced by manufacturer's printed literature, in order to be considered by the ARC for approval.
- C. The design of the house, including architectural style, detailing, and size of wall surfaces shall be considered by the ARC in determining acceptability of a vinyl product of siding. The ARC may, at its discretion, require modifications to wall surfaces including the addition of windows, doors, or breaks in the surface in order to reduce the number of locations that must be sided with long runs of vinyl requiring one or more vertical joints.
- D. Vinyl siding installation shall meet or exceed the standards in the handbook of the Vinyl Siding Institute. The following conditions shall automatically apply to each approval:
  - a. In any clear run of siding measuring 12'-0" or less (between openings, corners, projections, etc.) only single length panels shall be used. No vertical joints are permitted.

- b. In clear runs of siding over 12'-0", joints may be provided in a random pattern in the wall. Do not "stair-step" joint patterns. In clear runs greater than 12'-0" but less than 18'-0" in length, a maximum of one vertical joint is permitted in any horizontal line of siding. In clear runs greater than 18'-0" but less than 30'-0" a maximum of two joints are permitted in any horizontal line of siding.
- c. On the left and right sides of the house, all joints shall face to the rear of the lot. On the front of the house, joint directions shall face away from the direction of the entry.
- d. All trim except J-moldings at the ends of siding shall be wood, unless otherwise approved for specific neighborhoods, in which case the following conditions shall apply:
  - i. Trim pieces shall be manufacturer's standards preformed vinyl trims and manufacturer's standard pre-finished aluminum sheet.
  - ii. All right-angle corner joints at trim pieces shall be mitered at equal angles in similar fashion to wood joints. Joints at the base of rakes should be made similar to the direction of wood joints.
  - iii. Formed angles and edges of the metal trim sheet shall be fastened flat, and "dimpling" or "oil canning" shall be minimized.
- E. Other permitted siding materials include brick, stone, stucco, E.I.F.S., cement board (Hardie plank), and horizontal lap siding including wood or hardboard.
- F. Any additions to the house, including enclosing of screened porches or three season rooms, shall be of the same siding material as the main house structure. The design of this structure shall be compatible with and compliment the design of the house.

## 6.24 PAINTING, STAINING, AND COLORS

- A. All colors and painting schemes must be approved by the ARC prior to painting, staining, or any installation of pre-finished materials. All changes to existing colors and painting schemes must be approved by the ARC before the changes are accomplished. Painting in the original color shall not require ARC approval but may be submitted for record keeping reasons.
- B. The same or similar color schemes are not permitted on adjacent houses or on houses directly across from each other. The ARC may also reject a proposed siding color if it has been frequently used on houses in the immediate area. Siding material shall be painted with oil or latex based exterior house paint. Semitransparent stains and clear finishes are not permitted. Only factory colored vinyl siding shall be installed, and painting of vinyl is not permitted. If vinyl siding becomes faded, it may be painted in the original color.
- C. Primary colors of houses should be muted hues, such as browns, grays, creams, off-whites, and subtle rusts, blues, and greens. Compatible accent colors may be approved for doors and shutters.

Colors selected must be coordinated or compatible with other finishes such as masonry foundations and roof colors.

- D. Roofing must be dark colors such as gray, black, and brown. Red shades are not permitted.
- E. Applications will be considered using the following criteria.
  - a. The number of colors used must be limited to 1 for siding, 1 for trim, 1 for shutters and 1 compatible accent color for the front door.
  - b. Other structures such as storage buildings, gazebos, dog houses, and playhouses must be repainted at the same time as the house and match the house color.
  - c. Screening (lattice, etc.) between piers on front porches, decks, etc. must be painted, stained or factory colored vinyl to be consistent with the color scheme of the house.

#### 6.24.1 Application Requirements for Painting and Staining:

The following must be submitted with the completed application:

- A. A sample of the paint or stain and samples of the colors for the siding, trim shutters and door.
- B. A description of the areas to be painted or stained.

#### 6.25 PATIOS AND WALKWAYS

Approval is required for all proposed patios and walkways. Approval is also required for changes to all existing patios and walkways. An application will be considered using the following criteria:

- A. All materials must be of a neutral color, such as undyed broom finished concrete, exposed aggregate concrete, brick pavers, interlocking concrete pavers, or patterned (stamped) concrete. All front walkways must be a minimum of broom finished concrete or exposed aggregate concrete. Walkways must match the driveway when they join or are in close proximity.
- B. Walks of brick or exposed aggregate concrete, etc., designed as an integral part of the house and landscape must be provided from the driveway to the front door. Loose flagstones "dropped" on top of the ground in an ill-defined pattern are not acceptable.
- C. The design, location and size of patios and walkways must conform to the design and scale of the house and neighboring residences.
- D. Disturbing existing grades should be minimized. Any terracing (to follow existing land contours) required for a patio and/or walkway must be accomplished/constructed in SMALL increments.

- E. The location of a patio must provide reasonable visual and acoustical privacy for neighbors. Installation of screening, such as fencing or plantings, may be required to preserve such privacy.

#### 6.25.1 Application Requirements for Patios and Walkways:

The following must be submitted with the completed application:

- A. A site plan with dimensions showing the proposed walkway or patio in relationship to existing residences, trees and lot lines.
- B. A description and/or samples of materials to be used.
- C. A description of proposed lawn contour changes, plantings, screening, railings, benches, proposed exterior lighting, etc.

#### 6.26 PLAYHOUSES

Approval is required for any detached playhouse. No playhouse can exceed an area larger than 50 square feet. The wall height must not exceed seven (7) feet. All playhouses must be located in the rear and behind the sight line of the house.

- A. The design must be consistent with the existing shape, style, and proportion of the residence. Molded plastic models (primarily made for toddlers) are permitted provided they are removed when the property is sold or the children have outgrown them, whichever comes first.
- B. The finish and colors of siding, roofing, and trim materials must match the existing residence.
- C. The Playhouse must not impair the view, sunlight, or ventilation of adjacent residences or the use or enjoyment of open space or common areas.
- D. Tree houses and forts are not permitted.

#### 6.26.1 Application Requirements for Playhouses:

The following must be submitted with the completed application.

- A. A site plan describing the location of the playhouse on the applicant's property in relationship to property lines and neighboring residences.
- B. A drawing to scale or a manufacturer's description/brochure giving the specifications for the playhouse. This should include elevation views, dimensions, feature locations and any proposed exterior lighting.
- C. A description or sample of the exterior materials and colors.

## 6.27 POOLS - (Private)

Written ARC and Chesterfield County approval is required for all permanent in-ground pools.

NOTE: Chesterfield County MUST be contacted regarding applicable ordinances, required permits and seasonal pool drainage. A Chesterfield County building permit is required for pools deeper than twenty-four inches (24") or having a surface area of 150 square feet or more. Details for pool construction including barrier fencing is contained in the Chesterfield County pamphlet "Requirements for Outdoor Residential Swimming Pools".

- A. Above ground pools are not allowed.
- B. An application will be considered using the following criteria:
  - a. The size of the pool must be based on lot size and must be of reasonable proportion to the house.
  - b. Pools must be located wholly in the rear of the lot, not visible from the street, and not within 25' of a property line.
  - c. The ARC may require additional screening of pools to insure the privacy of neighbors.
  - d. All swimming pools shall be fenced in accordance with state and county building codes and in conformance with Section 6.11 Fences, of the BCA Standards & Guidelines.
  - e. The owner shall provide adequate drainage around lots to prevent standing water, particularly with filter backwash and pool water discharges.

### 6.27.1 Application Requirements for Pools - (Private):

The following must be submitted with the completed application:

- A. A site plan showing the location and dimensions of the pool, pool house, related equipment, fences, etc. in relation to the applicant's residence and property lines.
- B. A detailed drawing of the pool, deck, lighting arrangements, walkways, fence type, proposed grading, landscaping and information concerning the water supply system, drainage and water disposal system.

## 6.28 RECREATIONAL/PLAY EQUIPMENT

- A. Play equipment is often highly visible and depending on the design/application can defeat the aesthetic goals that the community seeks to achieve. Hence approval is required for all permanent (any item which remains in place for at least one season) exterior recreational/play equipment. Permanent equipment shall include, but not be limited to the following:
- a. SWING SETS
  - b. SLIDING BOARDS
  - c. JUNGLE GYMS — CLIMBING STRUCTURES
  - d. SANDBOXES
  - e. BASKETBALL STRUCTURES (Permanent and Portable)
  - f. TRAMPOLINES
- B. The equipment shall be located behind the rear sightline of the house as inconspicuously as possible and must be located at least 10' from the rear and side property lines. The primary support structure of play equipment must be of a natural wood color or if painted be a natural earth tone such as dark green or brown.
- C. The ARC may require that certain play equipment be screened from view. The standard requirement for screening will be to provide sufficient width and height of evergreen shrubs or trees of at least 2/3 the height of the play equipment. The screening when placed will provide a continuous screen to the equipment. Planting can be in a linear or staggered row. A variety of shrubs/trees may be used in addition to single shrub/tree species solutions. It shall be the responsibility of the homeowner to submit to the ARC a plan and proposed plant types for review.
- D. Mounting a basketball goal on a residence is prohibited. Permanent basketball structures (a metal pole cemented in the ground) may be installed provided they are located at the back edge of the driveway; consideration will be given to the side of the driveway as long as it is near the back edge. Portable basketball structures, when in use, are permitted in the front of the driveway of any residence during the day. They should be moved at the end of the day to the back of the residence or to an inconspicuous location. NOTE: Virginia State law prohibits recreational equipment (i.e. basketball structures) in the street.
- E. Trampolines are not permitted unless the homeowner can place the equipment in limited view and screened (see above 6.28.C.).
- F. Skateboard/Bike ramps are not permitted in Birkdale.
- G. Play equipment must be maintained to provide safety and prevent an unsightly appearance. If a valid complaint has been received regarding the lack of maintenance, and the homeowner fails to correct the violation (to comply with this section), then the ARC has the right to require removal of the equipment.

#### 6.28.1 Application Requirements for Recreational/Play Equipment:

The following must be submitted with the completed application:

- A. A site plan with dimensions showing the location of the recreation/play equipment in relation to the residence and property lines.
- B. A brochure, picture, or sketch of the proposed equipment showing dimensions, material and colors.

## 6.29 RESIDING AND RESTYLING

- A. It is the owner's responsibility to ascertain whether the proposed material meets Chesterfield County building and fire codes which may apply to exterior materials.
- B. When the proposed siding material differs in texture from existing siding, or if use of the residing material results in a change in architectural style, the replacement material must be compatible with the style of siding materials on residences immediately surrounding the applicant's residence.
- C. The style of existing trim work at soffits, corners, eaves, windows and doors and accent panels, shutters, or other stylistic features must be retained in the residing design. This will be considered an important requirement where these elements contribute to the visual continuity of the neighborhood by evoking similarities in style among nearby houses.
- D. The homeowner must match any existing storage shed with the same color siding of the resided/restyled home.

### 6.29.1 Application Requirements for Residing and Restyling:

The following must be submitted with the completed application.

- A. Photographs of the house as it currently appears including the color and texture of existing siding materials and the color and siding materials on immediately adjacent houses.
- B. A manufacturer's description and specifications of the proposed siding material, including the color and texture.
- C. Refer to siding installation requirements in Section 6.23 Siding.

## 6.30 ROOFS

- A. The minimum roof pitches permitted on the dominant roof are 8"/12" for one-story and two-story houses. Dormers, sheds, etc. may be treated differently if architecturally compatible. When large, shed dormers are utilized over garages, the rake

board and a portion of the roof, as it would occur without the dormer shall be continued to the normal eave height. Flat roofs or lesser pitches will only be considered by the ARC when they are integral parts of outstanding architectural design. As departures from the norm, they will be reviewed in the context of the total design of the house, its relationship to adjacent houses, and to its site. Permitted roofing materials shall include cedar, slate, and dimensional asphalt/fiberglass composition.

B. Roofing must be asphalt composition flat roof or fiberglass shingles or newer products that simulate asphalt or fiberglass shingles. Roof colors/shingle style will be approved based on compatibility with color scheme and style of house. Replacement of roof with same color/shingle style does not require approval if no other changes to the house are made (color and style of house). If the original information is not certain due to manufacturer changes, fading or roofing discoloration, a request should be submitted to ensure color and style compatibility. New products or technology, such as metal roofs with the appearance of shingles, will be evaluated when a request is submitted. Barn style metal roofing will not be approved.

C. No exposed natural (mill finished) aluminum or galvanized flashing is permitted. Color of all flashing must compliment adjacent surfaces. All gutters and downspouts must match trim.

D. No roof penetration (including skylights) are permitted on the front plane of roofs.

E. Small sections of roof such as bay windows or small porch coverings may be metal roofing as accent if approved by the ARC Committee.

F. Roofing guidelines may be affected by solar panel installations. Review shall be in compliance with section 6.33 and Virginia Code Section §55.1-1951.1 as necessary.

## 6.31 SERVICE YARDS

NOTE: The Birkdale ARC Guidelines & Standards document states in Section 7.02 B that "Trash containers must be properly screened and stored in such a manner so that they cannot be seen from the street and adjacent residences". Additionally, Section 3.15 of the Single Family Protections, a Declaration of Covenants, Easements and Restrictions states that "All trash cans and other trash receptacles shall be kept within the enclosed or screened area so as not to be visible from any street or adjacent Single Family Lot."

A. It is preferred that service yards be provided for every lot which incorporates HVAC equipment, generators, and trash receptacles.

B. The service yard(s) should be located on the side of the house with direct access to the driveway.

C. All service yards must be screened on the side fronting the street and adjacent residence. For corner lots, both sides fronting the street must be screened. Acceptable screening materials include wood (finished or unfinished and salt treated) vertical boards with a maximum of 1" spacing, wood posts and lattice, and vinyl posts and lattice. The screening must be properly supported, level, and plumb. The height must be at least as high as the equipment/item to be screened. The overall dimensions shall not exceed 5' in height, 5' in width and 8' in length.

D. Alternatively, homes that do not have service yards may store their trash cans in the garage or in the back of the house, hidden and not visible from the street. On the day of pick-up, trash cans may be moved to the front of the house or curb, and must be returned to the storage area by 7:00 p.m. on that day.

E. Recycling receptacles which are used to support curbside recycling program may be placed at the curbside on the day of the collection. Receptacles should not be placed at the curb until the morning of the collection and should be returned to their storage location by 7:00 p. m. on that day.

## 6.32 SIGNS

NOTE: Erection and placement of all signs must be in compliance with Chesterfield County ordinances and regulations.

- A. A professional temporary sign not more than 4 square feet belonging to a builder, realtor, or homeowner to advertise a lot and residence for sale or rent is permitted. Realtors will be permitted to use their logos, trademarks and color schemes.
- B. Temporary political signs are permitted per the Virginia State Code. Political signs may be placed in the front yard only and no more than 45 days prior to the date of voting in the pertinent election. These signs must be removed no later than 3 days following the date of the pertinent election. Signs left after this time will be removed by the Association. Political signs shall not be placed in any common areas.
- C. No other temporary or permanent sign or other advertising device of any nature will be permitted on a lot. The maximum height, as measured from the top of the sign to the ground, is 3 feet except for realtor posts which may be a maximum of 6 feet as measured to the top of the cross-arm.
- D. Signs must not be erected on trees, light poles, street or traffic signs.
- E. No more than one sign may be placed at any lot. Directional signs may be placed at corners as well as the entrances leading to an "Open House" event on a Saturday or Sunday. They must be removed no later than Sunday evening at 7:00 p. m.

- F. Signs must be neatly lettered, clean, have a professional appearance and be maintained in good condition.
- G. Only the Board is permitted to place signs announcing the semi-annual community yard sales. No individual homeowner signs can be placed anywhere in Birkdale advertising a yard sale.
- H. Signs advertising the services of a contractor which are on a homeowner's property while construction/repairs are taking place must be removed at the completion of the project.
- I. If any sign remains standing in violation of the above regulations, the sign may be removed by the Association. The Association will not be responsible for loss or damage of such signs.

### 6.33 SOLAR COLLECTORS

- A. Solar collectors represent a large visual impact on a residence due to their size. Therefore, it is important to properly integrate the collector into the design of the house to conceal it. Collectors must be located to give maximum advantage to the user and minimum visibility. Collectors shall not be mounted on the front slope of the house as it is designed. Side facing installations are acceptable but not desirable.
- B. Large collectors on a sloping roof must appear to be flush with the roof and not laying on top. Collectors on a flat roof must be set back and concealed with a parapet unless integrated with the roof design of the structure. Smaller collectors may be laid on top of a sloping roof and finished to appear like a skylight.
- C. Collectors must be constructed of glass with wood or metal trim. All trim must be painted to match the background color of the roof or house trim to conceal it. Plexiglas is not acceptable as it sags and yields an unsatisfactory appearance. All piping must be concealed.
- D. Freestanding collectors must be located behind the structure and completely concealed from the roads and adjacent properties or working with another architectural element.
- E. Review of an application for the installation of solar collectors is subject to provisions of Virginia Code § 55.1-1951.1. Installation of solar energy collection devices. (2021). Costs and productivity criteria must be considered in evaluating the request or proposing an alternative.

#### 6.33.1 Application Requirements for Solar Collectors:

The following must be submitted with the completed application.

- A. A site photograph or drawing of the residence including elevations, showing the location and appearance of the proposed solar collector.

- B. Details, which describe the dimensions of, the material used to construct the collector and how the edges of the collector meet the roof.

## 6.34 STEPS & PORCHES

Written approval is required for porches and steps. Any form of entry into a house may be included as a porch. The ARC recognizes ADA requirements as per the Virginia Uniform Statewide Building Code 2000 edition, effective October 1, 2003.

- A. Front entries including stoops and extended porches shall be constructed of finished materials matching the exterior of the house.
- B. Handrails and railing on front porches shall be constructed of vinyl, painted metal or wood and match the architectural style of the house.
- C. Porches constructed of concrete floors will be surrounded by a brick border from the height of the porch to the ground.
- D. Stoops and extended front porches shall be supported by either continuous foundations or on a minimum 12" by 12" brick piers.
- E. Open areas under extended front porches 12" greater in height above grade must be concealed with lattice. Any area less than 12" must be landscaped.
- F. All traditional exterior wood steps facing a street shall have closed and painted risers. All steps facing the golf course or visible from the street shall have closed and painted or stained risers.

### 6.34.1 Application requirements for Steps and Porches:

- A. Application must include scaled drawings of the porch, location, size, and type of materials to be used.

## 6.35 STORAGE BUILDINGS

NOTE: A Chesterfield County building permit is required for the construction of all sheds or storage buildings over 150 square feet in size and 102 inches or less in wall height.

- A. Written approval is required for construction or installation of all storage buildings. Approval is contingent upon the applicant building or installing a sturdy, permanent structure.
- B. Storage buildings may not be constructed of concrete block or metal.

- C. A storage building shall be of the same architectural style, same materials and have the same color scheme as the residence. Barn style sheds are not permitted unless there is a corresponding roofline on the main house.
- D. The storage building must be located in the rear of the home and as close to the house as possible; consideration will be given to other locations, however, provided that the storage building is well screened by natural coverings. Otherwise, the ARC may require additional planting/screenings in order to minimize the structure being obtrusive.
- E. If the house is restyled, resided, or a paint color change is made, the existing storage building must be altered to match the house.
- F. A storage building must not be larger than 10' X 12' and the maximum wall height of the building shall not exceed 8 feet.

#### 6.35.1 Application Requirements for Storage Buildings:

The following must be submitted with the completed application:

- A. A site plan showing the relationship of the storage building to the residence, property lines and adjacent residences.
- B. A picture and/or detailed drawing of the proposed storage building including dimensions.
- C. A description of materials to be used.
- D. The color scheme of the proposed storage building and applicant's residence.

#### 6.36 STORM/SCREEN WINDOWS AND DOORS

- A. Storm/screen windows and doors of straightforward design without decorative embellishments and which are compatible with the style and color of the house do not require prior approval. The storm/screen window or door must match (or blend with) the color of the house siding, exterior door, or trim. House trim constitutes two (2) or more of the following, in the same color: gutters and downspouts, shutters, corner molding, wide front door molding.

#### 6.36.1 Application Requirements for Storm/Screen Windows and Doors:

The following must be submitted with the completed application.

- A. Applications for storm/screen windows or doors other than those approved above must include descriptions of material, color, style, and any decorative embellishments.

### 6.37 SWIMMING POOLS - (Private)

- A. See 6.27. POOLS - Private.

### 6.38 TREE REMOVAL

- A. See 6.20. LANDSCAPING AND PLANTINGS.

### 6.39 WOODPILES

Written approval for woodpiles is not required.

- A. A woodpile must be neatly stacked in the rear of the lot. Stacking wood on sidewalks, driveways, rights-of-way or in open space is not permitted. (For protection against termites, residents are cautioned against stacking firewood too close to wood-frame residences.)
- B. Woodpiles will be limited to a reasonable amount of wood, generally not to exceed 4x4x8 (1 cord) or 3 face cords.

## VII OTHER STANDARDS

### 7.01 PROPERTY MAINTENANCE

- A. Property maintenance includes the upkeep of lots, buildings, and other improvements consistent with good property management, proper trash disposal and animal control. No tools, equipment, or materials (ladders, wheelbarrows, hand tools, lawn mowers, etc.) are permitted to be left or stored on property; these must be stored out of sight. If stored under decks, the decks must be screened; see DECKS 6.07.D
- B. Each Owner has the following responsibilities for General Property and Lawn Care:
  - a. Seeding, weeding, watering, and mowing of lawns, including any grass strip next to street or within drainage swells which may technically be within public road right of way.
  - b. Mowing grass to a height of no more than five (5) inches;
  - c. Pruning and care of all trees and shrubbery, including maintaining a minimum number of trees or shrubs at the front of the house.

- d. Snow removal from adjacent sidewalks and paths.
- e. Painting and external care of structures and other improvements including power washing as needed.

#### 7.02 TRASH (Refer to Section 6.31 Service Yards)

- A. Curbside pickup of trash is permitted. Trash and other refuse are to be disposed of on a weekly basis and no refuse, trash or bulk materials may be accumulated or stored on any lot
- B. Containers must be properly screened and stored in such a manner so that they cannot be seen from the street and adjacent residences.
- C. Curbside pickup of both trash and recycling materials only is allowed. No trash receptacles or recycling bins may remain in the front of the home past 7:00 p.m. that day.
- D. Builders/contractors are prohibited from fencing waste and construction debris and are required on each building lot or site to provide a roll off waste container of suitable size to accommodate waste from the construction of the building on the lot.
- E. Builders/contractors are required to pick up all debris and waste daily and place in waste container (see d above).

#### 7.03 ANIMAL CONTROL

- A. No wild, exotic or "game" type animals shall be kept on residential lots. No birds, animals or insects shall be kept or maintained on any lots except for domestic purposes (of or relating to a family or household).
- B. Residents are advised that they are subject to Chesterfield County ordinances regarding among other things licensing, "leash laws" and clean-up of animal waste material.
- C. All complaints concerning animals must be made to the Chesterfield County Animal Control Division.

#### 7.04 VEHICLES and PARKING

All vehicle parking in Birkdale must observe Chesterfield County Ordinances, including RVs, campers, driveways, cul-de-sacs, and more.

- A. Campers; house, horse and utility trailers; recreational vehicles; boats; school buses or commercial vehicles over 6,000 pounds having dual wheels; inoperable vehicles; any vehicle without current registration plates; or any similar items, shall not be stored or parked on any lot,

common area or street. These types of vehicles and items can only be parked in an area identified by the Association. If the Association does not identify such an area, they must be parked outside the development.

This definition of unauthorized vehicles follows Chesterfield Code Sec. 13-42 which is enforceable by the police department. The county department of Community Development follows similar limits for parking in residential areas but allows a vehicle weight limit up to 10,000 pounds. Additionally, angle parking is not allowed on any street unless specifically authorized by VDOT pursuant to Sec. 13-44.

- B. Major vehicle repairs may not be undertaken except in enclosed garages. Minor emergency repairs such as battery charging or changing, replacing a flat tire, and jump-starting are permitted in the open on any lot.
- C. A three-day period shall be allowed for RV and camper loading and unloading.
- D. Motor vehicle parking on the streets of the Birkdale community is a significant safety concern, e.g., children playing in the street behind a parked vehicle and when there is impeded ingress and egress of emergency vehicles. For this reason, it is important that ALL parking of motor vehicles by residents and/or guests be within the garage or access driveway attached to the single family house. No vehicles should be parked on the street in such a way that it impairs access to the street or a homeowner's access to their garage. Parking is not allowed on the lawn or anywhere else on the property other than the garage or driveway.

## 7.05 PORTABLE TOILETS

- A. Portable toilets are required during construction phases when permanent toilets on construction site are not in service or available for use. Portable toilets are to be placed not less than 20 feet from the street on which a lot fronts.
- B. Portable toilets are to be placed so that the doorway does not face the street on which the lot faces and must be maintained in such a manner so as not to be hazardous or obnoxious to the community.

## 7.06 PORTABLE STORAGE CONTAINERS

Portable storage containers are permitted to be used on driveways but are limited to one at a time and for no more than 2 weeks. Any variance to this must be approved by the ARC by submitting an application detailing the variance and why the variance is necessary.

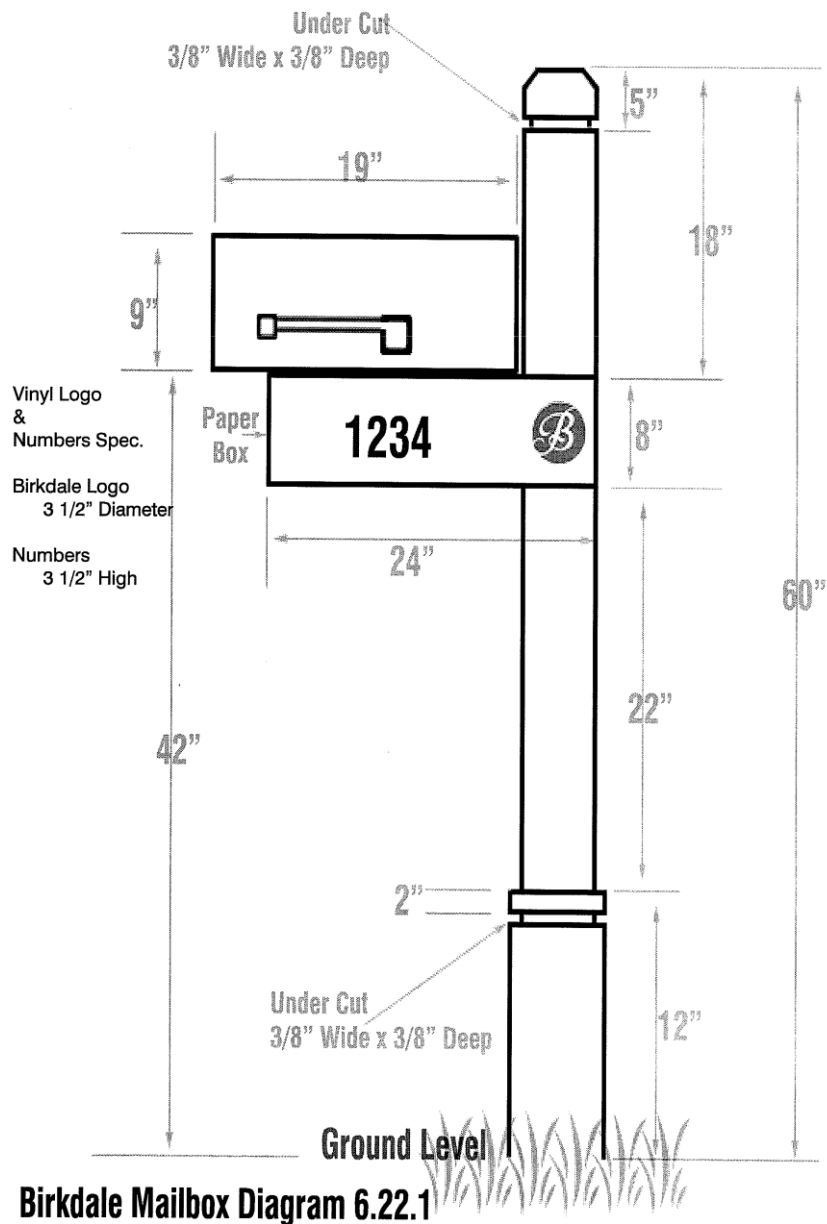

**Exhibit 1**

Post: 6" x 6" x 8' Pressure Treated Wood

Paper Box: (2) 1" x 6" x 23"  
(2) 1" x 8" x 23"

Base Moulding: (2) 1" x 6" x 12"  
(2) 1" x 8" x 12"



Mailboxes shall comply with US Post Office regulations including height (41-45 inches) and distance from the curb (6-8 inches).



# Birkdale Community Association

## Request for Architectural Approval (ARC)

When completed, please mail, fax or email application to ACS West, Lee Ann King, 1904 Byrd Ave. Ste 100, Richmond, VA 23230. Fax number is (804) 282-9590. Email: leeann@acswest.org

Property Owner's Name \_\_\_\_\_

Property Address \_\_\_\_\_

Telephone numbers (Home) \_\_\_\_\_

(Cell) \_\_\_\_\_

(Work) \_\_\_\_\_

Email Address \_\_\_\_\_

Submittal Date \_\_\_/\_\_\_/\_\_\_

=====

Complete the following if work is to be done by third party:

Business Name \_\_\_\_\_

Business Contact \_\_\_\_\_

Business Phone (Office) \_\_\_\_\_ (Cell) \_\_\_\_\_

Business Email \_\_\_\_\_

I. DESCRIPTION OF ALTERATION

- a. Describe in detail on the lines provided below, the changes you propose in accordance with the Birkdale Architectural Standards and the Declaration. Use additional pages if necessary and illustrate on a copy of your plat map the location of your improvement, if applicable. NOTE: CERTAIN TYPES OF ALTERATIONS REQUIRE A COUNTY BUILDING PERMIT. THE ASSOCIATION TAKES NO RESPONSIBILITY FOR OBTAINING THAT PERMIT. Call the Chesterfield County Building Inspector if you have questions.

b. Description of Project

---

---

---

---

---

---

---

---

---

II. ACKNOWLEDGEMENT OF ADJACENT OWNERS IMPACTED BY PROPOSED ALTERATIONS

- a. Your signature below shows you are aware of this application. It does not mean you approve the project. If you wish to discuss this proposal, contact the Architectural Review Committee or ACS West.

Name	Name
Address	Address
Phone	Phone
Signature	Signature
Date	Date

Adjacent Owner Comments:

---

---

---

---

---

---

---

---

---

---

---

III. OWNER’S UNDERSTANDING AND AGREEMENT:

I have completed this application in good faith and it accurately represents the alteration I propose to make. I UNDERSTAND THIS APPLICATION FOR ANY EXTERIOR CHANGES TO MY PROPERTY CANNOT VIOLATE ANY PROVISIONS OF THE ARCHITECTURAL STANDARDS, MASTER DECLARATIONS OR OF CHESTERFIELD COUNTY BUILDING AND ZONING CODES.

I agree any construction or alteration undertaken prior to receipt of the Architectural Review Committee’s approval is at my own risk. Should work proceed without ARC approval and found to be in non-compliance with the Architectural Standards, I may be required to return the property to its former condition in part or wholly at my own expense. I also understand non-compliance may also result in fines levied by the Association.

I permit representatives of the Architectural Review Committee to enter my property at any reasonable time for the purpose of evaluating the area for the proposed project, to inspect the work in progress, or the completed project and that such entry does not constitute trespass. The ARC will attempt to provide advance notice before any inspection of my project.

I understand work must be completed within 120 days after the ARC’s initial approval. I also understand the changes I have described in my application are the basis for ARC review and preliminary approval. Final ARC approval is contingent upon inspection of the completed project consistent with the description I provided in my application. I understand I am required to notify the ARC after the project is completed for final inspection and approval.

\_\_\_\_\_

Owner

\_\_\_\_\_/\_\_\_\_\_/\_\_\_\_\_  
Date

IV. ARCHITECTURAL REVIEW COMMITTEE (ARC) REVIEW

The ARC will process this application without undue delay, although they have up to 30 days for review. The procurement of additional required information may extend the processing time and in no way may be construed to be a waiver of authority by the ARC. The architectural review process is described in the governing documents and the rules. If you wish to discuss this application with the ARC, contact the ARC Chair. If you disagree with the decision of the ARC, a written appeal to the Board of Directors may be made within 10 days of receipt of the ARC decision.

ARC Form, Revised December 2023– This form replaces all previous documents.

V. ARCHITECTURAL REVIEW COMMITTEE (ARC) APPLICATION REVIEW:

ARC approval or rejection will be tracked in SMARTWEBS project management program.

ARC Form, Revised December 2023 – This form replaces all previous documents.

